

# spring... ON THE ROAD

## General Lee, found in a barn



PHOTOS BY ROXIE MURPHY

BY ROXIE MURPHY  
ADVOCATE STAFF WRITER  
rmurphy@wardpub.com

Ryan Scott has always loved the look of the classic Dodge Chargers. Maybe it's the slick bodyline, the ready-for-speed personality they project, or the way the engine rumbles beneath the heavy, metal hood. He speculates that his love for the 1969 Charger probably came from the famous TV series *Dukes of Hazzard*, which explains why Scott painted the car to have a General Lee of his own.

"I literally found it in a barn," said Scott, who owns Sunset Heating and Air Conditioning. "I had known about it for years."

The previous owner, Daryl Giedinghagen, had a nephew in the same class as Scott

Jeremy King, son of Giedinghagen's sister Marylis King, would sometimes talk about restoring the car, but he eventually moved away. The car's location was known, along with the knowledge that Giedinghagen wouldn't sell.

The two-owner vehicle was parked in its early days. The Charger had been purchased new in January 1970 from Wehmeyer Motor, Inc. in Rosebud by a gentleman who had bought it for his wife. However, his wife didn't like the car and they traded it back to Wehmeyer's in October 1971 with 163 miles on the engine.

A year later Giedinghagen came home from Vietnam with his army salary saved up.

"His dad told him to go down to Wehmeyer's and buy a vehicle," Scott said. "Daryl brought the car home and his dad ripped him up and down, 'I can't believe you bought a car that is going to drag the bottom all the way down the driveway.'"

The family lived on the outskirts of Belle on Highway Y, a mile-and-a-half down another drive, then another two miles to the bottom of a private drive.

Giedinghagen's father purportedly told his son to take his remaining savings back to Wehmeyer's and the second time he brought home a 1968 GMC pick-

See **Charger**, Page 14



908 Hwy 63 South • Vienna  
573-578-2233

**FAST LANE TOWING & Recovery, LLC**  
24/7  
573-578-2233

Chip Repair & Replacement ✓ ✓ Home & Auto

**Double Check Glass Service, LLC**

"We check it twice, to make sure it's right"

**Mobile: 573-694-1524**  
Fax: 573-493-2592  
Email: dcheck.shane@aol.com  
Vienna, Missouri  
Shane Hoecker, Owner/Technician

**Paint & Bodywork Specialists**

**RODGERS Autobody COLLISION REPAIR**

ADAMRODGERS16@YAHOO.COM • 20774 MARIES RD. 310, BELLE • 573.680.5578

## Who knew?

We could shop 8 Different Companies to find the lowest rates for your auto insurance.

- Dairyland
- Travelers
- Progressive
- Grinnell Mutual
- United Home
- Hagerty
- Gainsco
- Graham-Rogers

Call or stop in for a policy review and free quote.

**Curtman Insurance Agency**  
Bryan Curtman & Sherri Biermann  
111 South 1st Street • Owensville, MO 65066  
curtmanagency@gmail.com  
**(573) 437-8258**  
~ Farm ~ Home ~ Business ~ Auto ~ Life ~ Accident ~ Special Events

**Hicks Auto Sales & Autobody**

573-646-3820  
1200 Highway 28 • Bland, MO  
www.HicksAutoSales.com

'16 Silverado 2500HD LTZ Crew Cab 4WD, 110,xxx mi. \$39,950

'18 Colorado Crew Cab Z71 4WD 142,xxx mi. \$28,950

'01 Ram 2500 Ext. Cab 4WD 231,xxx mi. \$14,950

'20 Dodge Grand Caravan SE 120,xxx mi. \$15,950

REDUCE • REUSE • RECYCLE • REDUCE • REUSE • RECYCLE

**RECYCLING ZONE**

573-437-5050  
1640-B, Highway 28 • Owensville, Missouri 65066

**TOP DOLLAR** Paid for  
Car Radiators & Batteries  
Catalytic Converters Much More!

**WE ALSO PAY TOP DOLLAR FOR:**  
All Types of Aluminum ~ Copper ~ Brass

Why trade it in? Sell it for more \$\$\$

Get Cash for it!

REDUCE • REUSE • RECYCLE • REDUCE • REUSE • RECYCLE

**HALLER Automotive**  
573-422-9904

**Trusted Service & Repair**  
cars | trucks | vans  
foreign | domestic

Including: AC Repair  
General Automotive Repair  
Alignments | Oil Changes  
Batteries | Brakes | Tires  
State Inspections

908 Hwy 63 South | Vienna Mo | 573-422-9904  
(former Weidinger Chevrolet building)



**Charger • from page 13**

up truck. His dad wouldn't let him drive the car, so it stayed parked in the barn.

"Marlis King, his sister," said he only drove the car six times and parked it in the barn in 1977 with 325 miles on the 318 cubic inch engine," Scott said.

Hotrod red with a white vinyl top, the Charger was mostly protected from the elements in the barn, but as the owners got older, the barn began to deteriorate. Then about six years ago a truss in the barn broke and went through the side window of the charger.

"The barn was coming down on top of the car," Scott said. "Doug? Went to Marlis? And said 'hey, you want me to pull out that old car before the barn comes down?'"

They pulled the car out and haphazardly tarped it, but the broken window allowed the rain and moisture in. Eventually the seats turned green with mold. Still it sat.

Giedinghagen was starting to forget things and his sister Marlis was named executor and caretaker. In 2020 Giedinghagen's washing machine stopped working and Marlis called Scott to see if he could fix it.

"Me and Tanya (Scott's girlfriend) were on our way out there and I was telling her all about this car," he said. "Before we left, I told her I was going to make Marlis mad."

Scott asked Marlis when she was finally going to sell him that car and she said they were putting it up for sale the next day.

"I said, tell me how much you want for it and I will go to the bank right now," he said.

Marlis named a price and Scott returned that evening.

"I didn't have a way to get the car out, so I called Daryl White (Jr.) and asked him to haul a car for me," Scott said. "I didn't know he and Daryl, Sr., had tried several times to buy the car over the years and Giedinghagen always said no. He was silent for about 15 seconds and then asked, 'you bought that car, didn't you?'"

Scott said he had bought the car. "If you have ever seen anyone doing work with a disgruntled look on his face, it was Daryl White (Jr.)," Scott said.

Before dropping the car off, White parked it under the lights at Thomas Quick Stop and took pictures.

"I have had so many offers to buy that

See **Charger**, Page 15



PHOTOS ABOVE BY ROXIE MURPHY, BELOW, SUBMITTED



**RYAN SCOTT** (lower left) sit proudly in his restored 1969 Dodge Charger. The Charger runs on a 362 small block V-8, bored 30 over with a hydraulic roller cam, an Edelbrock four-barrel manifold and a 750 CFM aluminum double pumper carburetor. It has been restored to resemble one of the first five General Lees from the 1979 TV show Dukes of Hazzard.



**A Winning Combination!**

Call me today to see how you can take advantage of this winning combination from Shelter!

**Tonya Jacquin**  
573 859-3831

36063 Hwy. 28W • Belle Mo.



We're your Shield.  
We're your Shelter.



573-744-9100 | 203 N HWY 63 | FREEBURG, MO 65035

**EVERYTHING YOU NEED TO KEEP YOUR CAR IN TOP SHAPE AT YOUR ONE-STOP SHOP FOR SAVINGS**



**NAPA OF VIENNA**  
VIENNA AUTO SUPPLY, INC.  
506 HWY. 63 SOUTH VIENNA  
573-422-3638



**63 Auto & Truck Parts LLC**  
13986 Highway 63 • Vichy  
Just north of the Vichy Wye on Hwy. 63

**573-299-4300**  
Used Auto Parts from late 90s to current vehicles

Used batteries from \$30 with core

Hours: 8-5 p.m.

Monday thru Friday

Current inventory can be seen on car-part.com

Mike Prigge • Logan Prigge

**H & M COUNTRY STORE LLC**

Come by and experience "Down Home Service & Hospitality" at Bland's locally owned convenience store!



**573-646-3028**  
203 E. Colorado Street, Bland, MO 65014  
KMCountryStore@gmail.com



*When Good as New Isn't Good Enough*

Professional Auto Body, Paint & Restoration

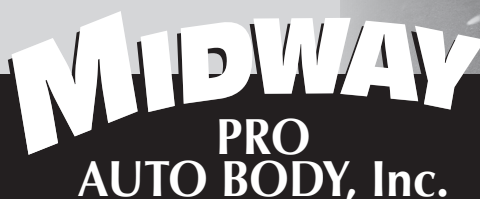

**573-422-3961** 33711 HWY. 63 NORTH • VIENNA  
Todd Schoene, Owner pbschoene2015@gmail.com



**RAINERI Transmission & Auto Service**

Complete Power Train Service

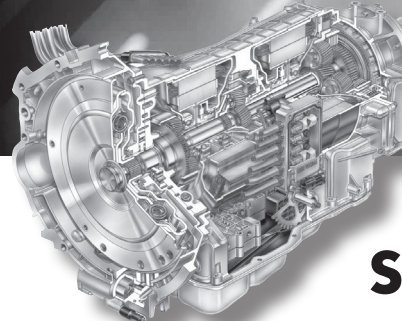

**SPECIAL TRANSMISSION SERVICE AND REAR ENDS**

...on Autos, Foreign Cars and Large Trucks!

**ALSO STATE INSPECTIONS**

**MANUAL. AUTOMATIC. CARS. BIG TRUCKS. SERVICE. QUALITY. RELIABILITY. ECONOMY.**

The next time you suspect transmission trouble, count on us. No matter what type of car you have, you'll find our level of service is way above standard.

WE ALSO CAN HANDLE FRONT END SUSPENSION, BRAKES AND SOME ENGINE WORK

Call for an appointment today

**573-437-8470**

605 Raineri Circle • Owensville, MO 65066

